



## INTERNATIONAL MIRAGE® STANDARD COUNTERTOP INDUCTION RANGES



### DESCRIPTION

The ultra-low profile, portable countertop induction range is designed for use in light to medium-duty front-of-the-house cooking.

The induction ranges are equipped with a variety of safety features including:

- Over-heat protection
- Small-article detection
- Pan auto-detection function
- Empty-pan shut-off
- Safety auto-shut-off function

### WARRANTY

All models shown come with Vollrath's standard warranty against defects in materials and workmanship. For full warranty details, please refer to [www.Vollrath.com](http://www.Vollrath.com).

- This appliance is intended for use with induction-ready cookware with a flat base with a minimum diameter of 4¾" (12.1 cm).
- Not intended to be used with aluminum pans with a metal disk on the bottom.

### AGENCY LISTINGS



### ITEMS

- 59650 Countertop Range, Schuko Plug
- 59651 Countertop Range, UK Plug
- 59652 Countertop Range, China Plug
- 59655 Countertop Range, AU Plug

### FEATURES

- 1-100 power levels or °F/°C temperature level controls
- 90% efficiency rating
- Easy to read digital readout for power level
- 1-180 minute timer
- The case frame is made from heavy-duty, 18-gauge stainless steel with a ceramic top
- The top displays HOT when unit is turned off, if the cooking surface is still hot
- Variable speed knob for fast temperature adjustment
- Rubber feet to prevent slipping of appliance
- 6-ft. (183 cm) cord with plug

### CLEARANCE AND ENVIRONMENT REQUIREMENTS

- Indoor use only.
- Minimum required clearance is 4 inches (10.2 cm) at the rear and ½ inch (1.3 cm) at the bottom.
- All models require unrestricted intake and exhaust air ventilation for proper operation of the controls.
- The maximum intake temperature must not exceed 110°F (43°C). Temperatures are measured in ambient air while all appliances in the kitchen are in operation.
- This equipment requires a dedicated circuit.

Precio de exposición 520 € + IVA



**INTERNATIONAL MIRAGE® STANDARD COUNTERTOP INDUCTION RANGES**

**DIMENSIONS** (Shown in inches (cm))

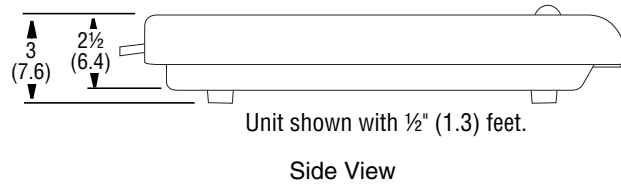
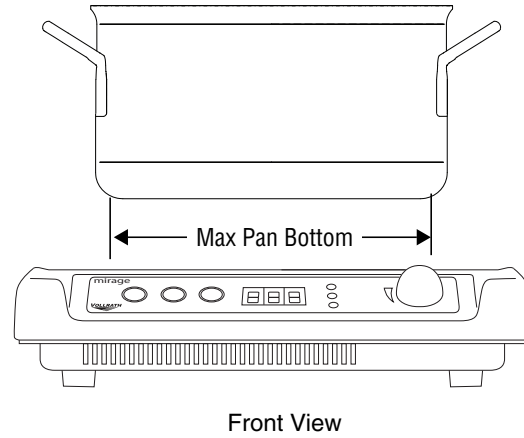
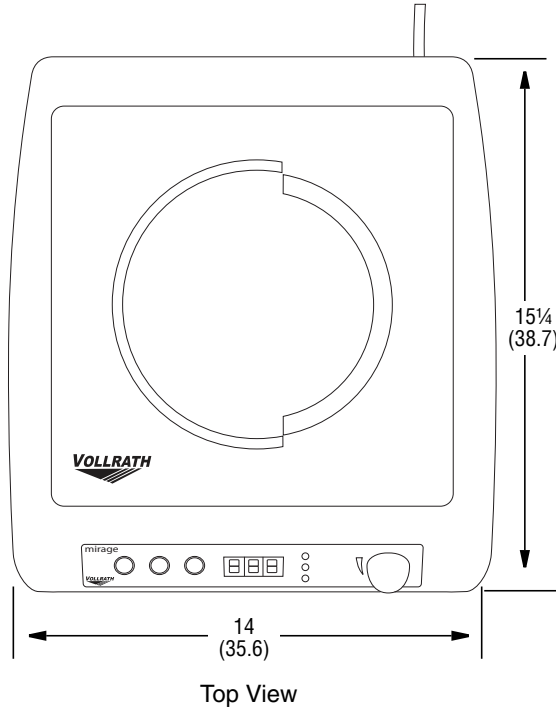

**SPECIFICATIONS**

Item No.	Max Pan Diameter* IN (CM)	Volts	Watts	Amps	Phase	HZ	Plug	Weight LB (KG)
59650	10 1/4 (36.0)	230	1800	7.8	1	50/60	Schuko	12.8 (5.8)
59651							UK	
59652							China	
59655							AU	

**Receptacles**

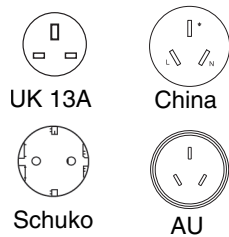

\* Maximum pan diameter is provided as a guideline for achieving maximum performance. Cookware with a larger base diameter can be used, however only the area of the cookware above the induction coil will heat. The more cookware extends past the coil, the more the overall performance will be reduced. Other factors impact performance including pan construction, material, the density and volume of the food in the pan, ambient temperature and food temperature. Cookware with inferior construction or material may not perform well.